

CENTADISC®



# CENTADISC-C

ENGLISH

Is this PDF up to date?  
[click here for an update check!](#)

# CENTADISC-C

# OUR LIGHTWEIGHT

---

## SYSTEM

---

### At a glance

Page 03

---

---

## AREAS OF APPLICATION

---

### Product selection: Which coupling for which purpose?

Page 05

---

---

## TECHNICAL DATA

---

### Product application: Which feature for which coupling

Page 07

---

---

## SERVICE

---

### Special types

Page 12

---

### Explanation of the technical data

Page APP-1

---

### Contact

Page APP-6

---

Is this PDF up to date?  
[click here for an update check!](#)

# CENTADISC-C

## AT A GLANCE

CENTADISC-C – a torsionally stiff light weight membrane coupling for the application in vessels, ferries and in wind energy applications where weight and alignment are of importance. Two membranes arranged in series and combined with a fibre reinforced tube function as kinematic joint with optimum operating characteristics. The combination with further CENTA products, cardanshafts, homokinetic joints or couplings on the other shaft end guarantee for optimal adaption.

Stiff and lightweight tubes allow for high bending speeds thus longer driveshafts are possible in with substantially reduced bearings.

Main feature of type H it the positive fit of all components by standardized, shaft-end toothing between coupling element and tube or power unit. Easy handling due to modular design and standardization.

### Features

- high bending speeds
- low weight
- maximum mounting ease
- resistant to corrosion

### Areas of application



torque range	1 to 45 kNm
elastic material	PA / GFK
temperature range	-40° to +150°C

# LEADING BY INNOVATION

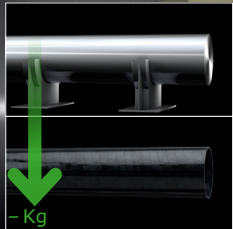

## LIGHTWEIGHT

Lightweight solutions often are subject to comprise in regard of torsional stiffness. The use of light materials on CENTADISC-C though make it possible and ensure safe transmission of high speeds up to 45 kNm.

The CENTADISC-C results in a cost effective solution for vibration and noise damping.

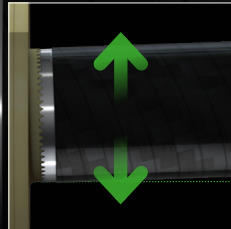

## COMPENSATION OF MISALIGNMENTS

The couplings of the CENTADISC series compensate for significant misalignments in axial, radial and angular directions.

They are the ideal solution for applications with demanding misalignments.

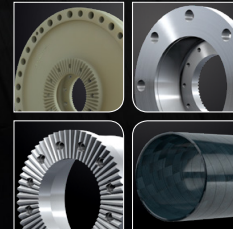

## MODULARITY

The combination with further CENTA products, cardanshafts, homokinetic joints or couplings on the other shaft end guarantee for optimal adaption and appropriate design solutions for practically any application where light weight is a must with very little effort. The CENTADISC-C is available as homokinematic shaft (in Carbon or glasfibre design).



## ASSEMBLY

The maintenance effort is very low and upon intended use there is no abrasion.

The coupling is ready for radial exchange.

Furthermore a specific shaft-end toothing ensures axial division of the flange mounting and membrane joint as well as tubes or spacers.



## QUALITY

When the going gets tough, quality is priceless. With an exemplary Quality Management, CENTA ensures products that withstand the roughest assignments. CENTA's coupling systems are more than the sum of their parts. CENTA entertains the vision of intelligent products that meet the highest requirements in terms of design and quality.

## CENTADISC-C

# APPLICATIONS

Which product for your purpose?  
We will gladly assist → [www.centa.info/contact](http://www.centa.info/contact)

# CENTADISC-C APPLICATIONS

## MARINE APPLICATIONS

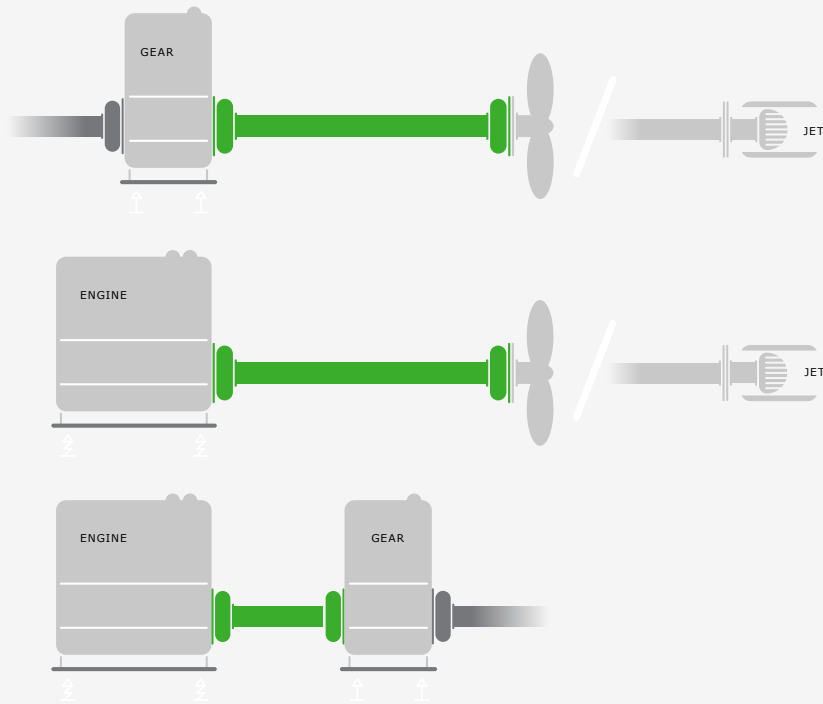

## WIND APPLICATION

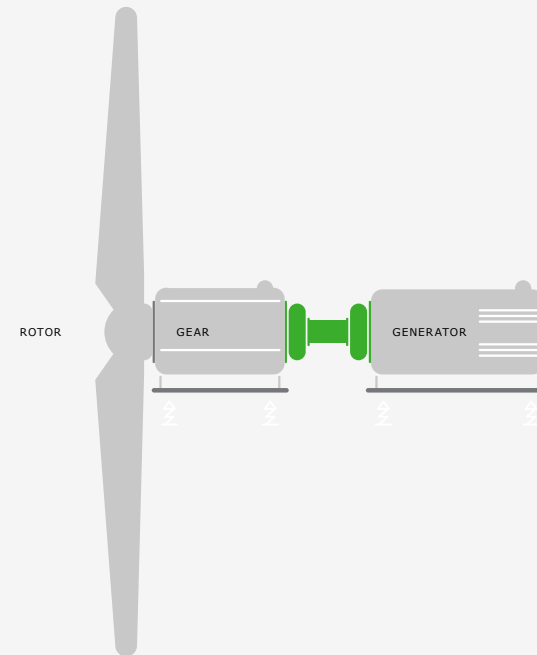

Which product for your purpose?  
We will gladly assist → [www.centa.info/contact](http://www.centa.info/contact)

# CENTADISC-C

# TECHNICAL DATA

---

## TECHNICAL DATA

---

**Sizes 0H-5H** Page 08

---

**Sizes 0G-4G** Page 10

---

---

## DIMENSIONS

---

**Sizes 0H-5H** Page 09

---

**Sizes 0G-4G** Page 11

---

Questions on product selection?  
We will gladly assist → [www.centa.info/contact](http://www.centa.info/contact)

# CENTADISC-C

## TYPE H

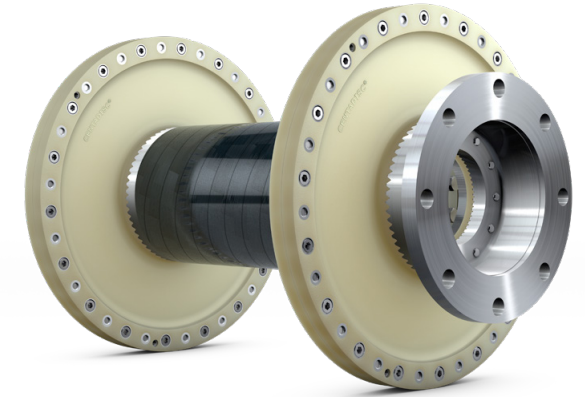

### TECHNICAL DATA

↓ SIZE 0-5

1	3	4	5	7*	9	10*	11*	14*	15*
Size	Nominal torque	Maximum torque	Continuous vibratory torque	Dynamic torsional stiffness	Speed	Permissible axial displacement	Axial stiffness	Permissible angular stiffness	Angular stiffness
	$T_{KN}$ [kNm]	$T_{Kmax}$ [kNm]	$T_{KW}$ [kNm]	$C_{Tdyn}$ [kNm/rad]	$n_{max}$ [min <sup>-1</sup> ]	$\Delta K_a$ [mm]	$C_a$ [kN/mm]	$\Delta K_w$ [°]	$C_w$ [kNm/°]
0	2,0	4,0	0,5	145	4000	2	0,40	2,2	0,09
1	5,0	10,0	1,25	460	3500	3	0,59	2,0	0,20
2	9,0	18,0	2,25	730	2900	3	0,67	1,6	0,34
3	16,0	32,0	4,0	1350	2500	3	1,04	1,5	0,47
4**	25,0	50,0	6,25	2600	2200	3	3,18	1,1	1,88
5**	45,0	90,0	11,25	5100	1800	3	3,38	0,8	3,05

\* per membrane set

\*\* on request



# CENTADISC-C

## TYPE H

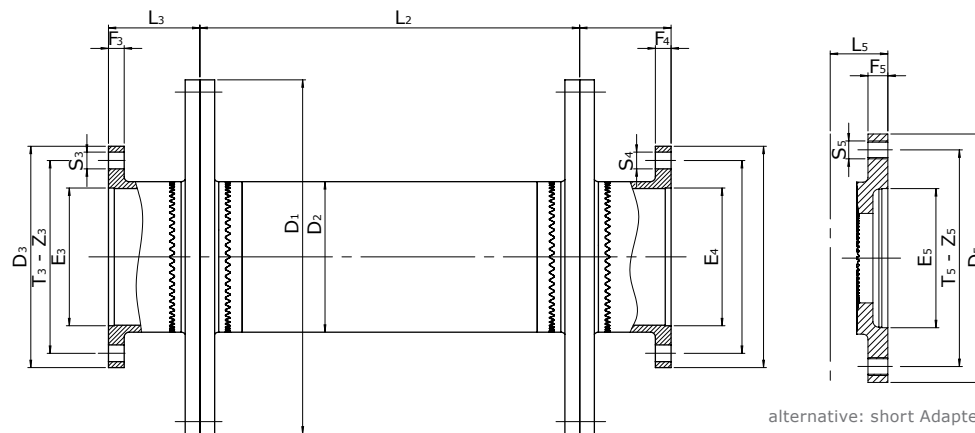

**DIMENSIONS**

↓ **SIZE 0-5**

Size	D <sub>1</sub>	D <sub>2</sub>	D <sub>3</sub> /D <sub>4</sub>	D <sub>5</sub>	E <sub>3</sub> /E <sub>4</sub> [H7]	E <sub>5</sub> [H7]	F <sub>3</sub> /F <sub>4</sub>	F <sub>5</sub>	L <sub>2</sub>		L <sub>3</sub> /L <sub>4</sub>	L <sub>5</sub>	S <sub>3</sub> /S <sub>4</sub>	S <sub>5</sub>	T <sub>3</sub> /T <sub>4</sub> ±0,2	T <sub>5</sub> ±0,2	Z <sub>3</sub> /Z <sub>4</sub>	Z <sub>5</sub>
									min	max								
0	280	112	180	180	110	110	16	16	230	4280	95	58	14,1	M14	155,5	155,5	8	8
1	360	155	225	250	140	140	16	20	220	4080	92,5	58	17	M18	196	218	8	8
2	430	212	315	285	175	175	22	22	250	5990	101	65	22,1	M22	280	245	8	8
3	500	266	350	350	220	220	22	22	260	6080	111	65	23	M22	310	310	10	10
4**	580	312	435	435	280	280	27	27	300	9500	125	75	28	M27	385	385	10	10
5**	700	414	550	550	400	400	27	27	400	9100	130	75	28	M27	500	500	10	10

\*\* on request

# CENTADISC-C

## TYPE G

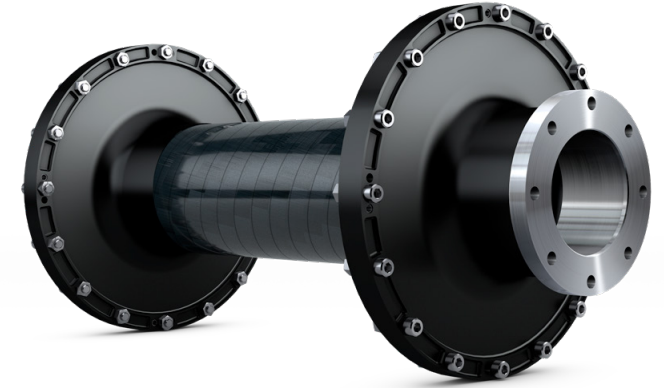

**TECHNICAL DATA**

↓ **SIZE 0G-4G**

1 Size	3	4	5	7*	10		14	
	Nominal torque $T_{KN}$ [kNm]	Maximum torque $T_{Kmax}$ [kNm]	Continous vibratory torque $T_{kw}$ [kNm]	Dynamic torsional stiffness membrane $C_{membrane}$ [kNm/rad]	Permissible axial displacement short termed	continuous	Permissible angular stiffness short termed	continuous**
					$\Delta K_a$ [mm]		$\Delta K_w$ [°]	
0G	1,6	3,2	0,40	120	± 3	± 2,0	2	1,3
1G	3,0	6,0	0,75	140	± 4	± 2,6	2	1,3
2G	6,0	12,0	1,50	490	± 5	± 3,3	2	1,3
3G	12,0	24,0	3,00	900	± 6	± 3,9	2	1,3
4G	20,0	40,0	5,00	1500	± 7	± 4,6	2	1,3

\* per membrane set

\*\* continuous allowable value for DNV classification is 1°

# CENTADISC-C

## TYPE G

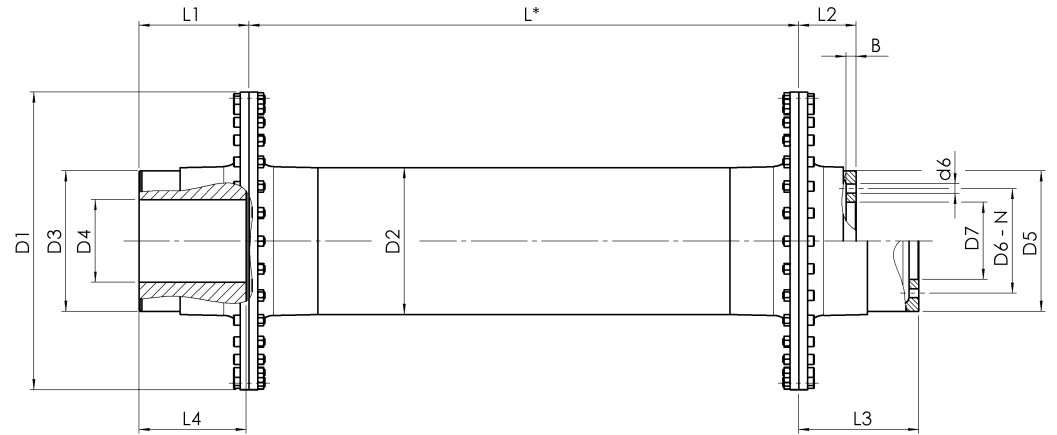

### DIMENSIONS

### ↓ SIZE 0G-4G

Size	D <sub>1</sub> [mm]	D <sub>2</sub> =D <sub>3</sub> max. [mm]	D <sub>4</sub> [mm]	L <sub>1</sub> [mm]	L <sub>2</sub> [mm]	L <sub>3</sub> [mm]	L <sub>4</sub> [mm]	D <sub>5</sub> [mm]	D <sub>6</sub> ± 0,1 [mm]	D <sub>7</sub> [mm]	N	d <sub>6</sub> [mm]	B [mm]	Mass moments of inertia and masses					
														J <sub>1</sub> [kgm <sup>2</sup> ]	J <sub>2</sub> =J <sub>3</sub> [kgm <sup>2</sup> ]	J <sub>4</sub> [kgm <sup>2</sup> ]	m <sub>1</sub> [kg]	m <sub>2</sub> =m <sub>3</sub> [kg]	m <sub>4</sub> [kg]
0G	280	112	65	95	77	102	90	143	120,65	95,25	4	Ø 13	12	0,0158	0,0145	0,0116	5,8	2,6	1,7
1G	350	153	90	105	85	160	100	180	155,5	110	8	M 14	20	0,0523	0,0431	0,0435	11,8	4,5	4,8
2G	450	212	135	169	70	169	160	212	155,5	110	8	M 14	14	0,2434	0,1159	0,0957	37,0	6,5	6,0
3G	540	266	170	200	104	200	195	266	218	140	8	M 18	23	0,7097	0,2998	0,2910	69,9	10,8	13,3
4G	600	312	200	225	97	225	220	312	245	175	8	M 20	20	1,439	0,465	0,444	104,8	13,0	15,6

Dimension L\* is produced according customers requirements, but is nevertheless dependant upon speed. We are at your service for consultation.

The dimensions of the connecting flanges (D<sub>5</sub>, D<sub>6</sub>, D<sub>7</sub>, d<sub>6</sub>) comply with our company standards.

Deviating tailored flanges are possible. Each side of the universal joint shaft can either be equipped with hubs or connecting flanges.

The flanges are available with dimension L<sub>2</sub> in short version or with dimension L<sub>3</sub> in long version. The materials available for hubs and flanges are steel, aluminium or titanium.

# CENTADISC-C

## SPECIAL TYPES

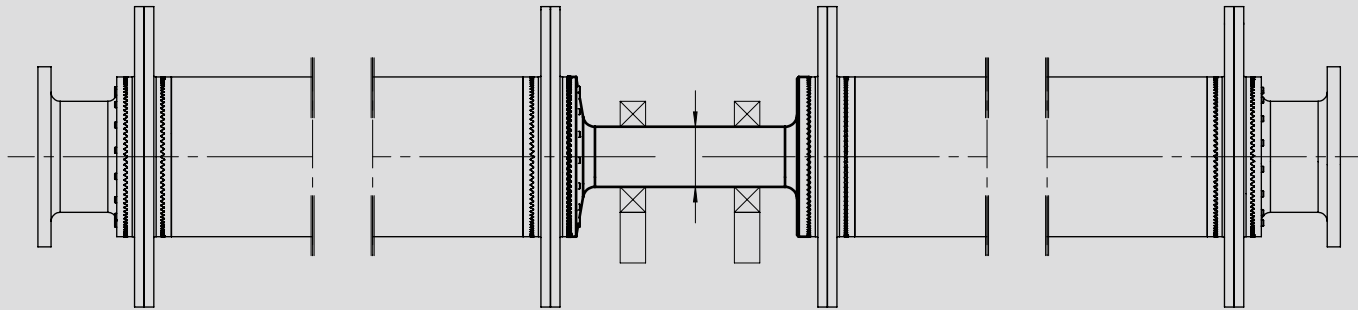

Driveshaft with supported double bearing countershaft.

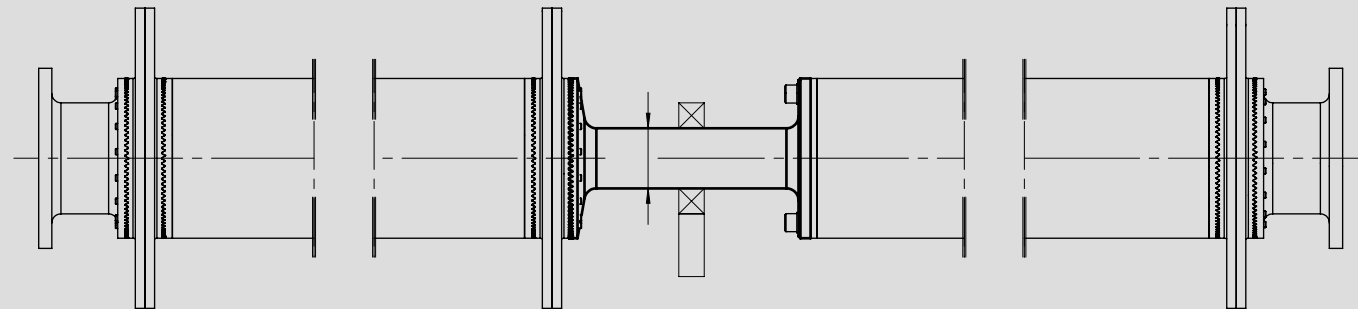

Driveshaft and countershaft with only one bearing. Spherical adjustment of the bearing must be possible.

# EXPLANATION OF THE TECHNICAL DATA

This appendix shows all explanations of the technical data for all CENTA products.

**the green marked explanations are relevant for this catalog:**

1	Size	Page APP-2
2	Rubber quality	Page APP-2
3	Nominal torque	Page APP-2
4	Maximum torque	Page APP-2
5	Continuous vibratory torque	Page APP-2
6	Permissible power loss	Page APP-2
7	Dynamic torsional stiffness	Page APP-3
8	Relative damping	Page APP-3
9	Speed	Page APP-3
10	Permissible axial displacement	Page APP-3
11	Axial stiffness	Page APP-4
12	Permissible radial displacement	Page APP-4
13	Radial stiffness	Page APP-4
14	Permissible angular displacement	Page APP-4
15	Angular stiffness	Page APP-4

Are these technical explanations up to date?  
[click here for an update check!](#)

# CENTADISC-C

## EXPLANATION OF THE TECHNICAL DATA

1
Size

This spontaneously selected figure designates the size of the coupling.

2
Rubber quality Shore A

This figure indicates the nominal shore hardness of the elastic element. The nominal value and the effective value may deviate within given tolerance ranges.

3
Nominal torque $T_{KN}$ [kNm]

Average torque which can be transmitted continuously over the entire speed range.

4
Maximum torque [kNm]

$T_{Kmax}$  This is the torque that may occur occasionally and for a short period up to 1.000 times and may not lead to a substantial temperature rise in the rubber element.

In addition the following maximum torques may occur:

$\Delta T_{Kmax} = 1,8 \times T_{KN}$  Peak torque range (peak to peak) between maximum and minimum torque, e.g. switching operation.

$T_{Kmax1} = 1,5 \times T_{KN}$  Temporary peak torque (e.g. passing through resonances).  $\Delta T_{Kmax}$  or  $T_{Kmax1}$  may occur 50.000 times alternating or 100.000 times swelling.

$T_{Kmax2} = 4,5 \times T_{KN}$  Transient torque rating for very rare, extraordinary conditions (e.g. short circuits).

5
Continuous vibratory torque $T_{KW}$ [kNm]

Amplitude of the continuously permissible periodic torque fluctuation with a basic load up to the value  $T_{KN}$ .

The frequency of the amplitude has no influence on the permissible continuous vibratory torque. Its main influence on the coupling temperature is taken into consideration in the calculation of the power loss.

Operating torque $T_{Bmax}$ [kNm]
--------------------------------------

The maximum operating torque results of  $T_{KN}$  and  $T_{KW}$ .

6
Permissible Power Loss $P_{KV}$ [kW] or [W]

Damping of vibrations and displacement results in power loss within the rubber element.

The permissible power loss is the maximum heat (converted damping work into heat), which the rubber element can dissipate continuously to the environment (i.e. without time limit) without the maximum permissible temperature being exceeded.

The given permissible power loss refers to an ambient temperature of 30° C.

If the coupling is to be operated at a higher ambient temperature, the temperature factor  $S_{tPKV}$  has to be taken into consideration in the calculation.

The coupling can momentarily withstand an increase of the permissible power loss for a short period under certain operation modes (e.g. misfiring).

$P_{KVZ}$ [kW]
----------------

Defines an individual and proven guide for power loss under misfiring. This value acknowledges general information of the engine suppliers, in particular the real appearance of misfiring and implemented control and protection devices. Values on request.

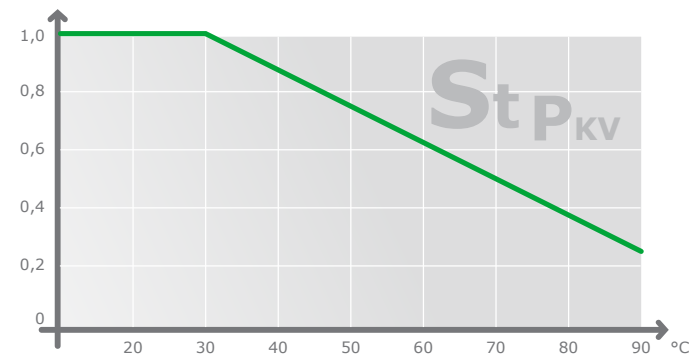

# CENTADISC-C

## EXPLANATION OF THE TECHNICAL DATA

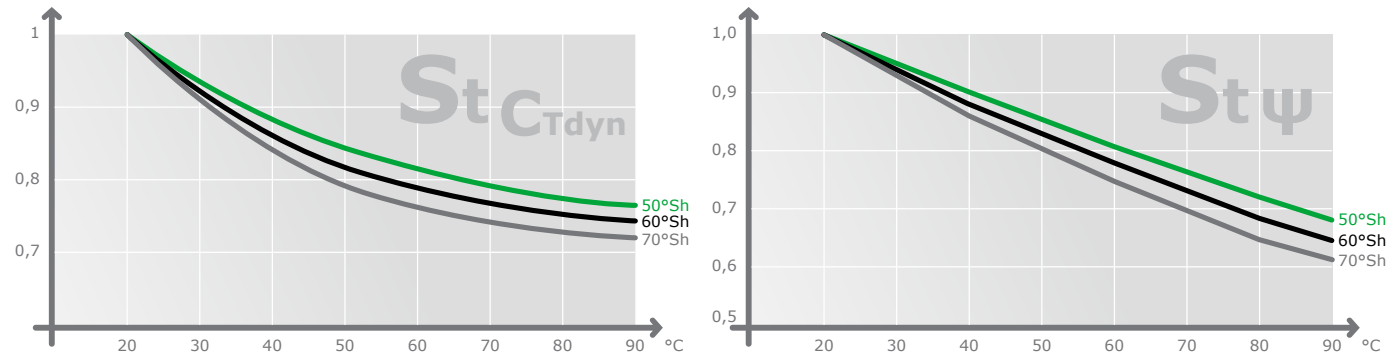

7
Dynamic torsional stiffness $C_{Tdyn}$ [kNm/rad]

The dynamic torsional stiffness is the relation of the torque to the torsional angle under dynamic loading.

The torsional stiffness may be linear or progressive depending on the coupling design and material.

The value given for couplings with linear torsional stiffness considers following terms:

- Pre-load: 50% of  $T_{KN}$
- Amplitude of vibratory torque: 25% of  $T_{KN}$
- Ambient temperature: 20°C
- Frequency: 10 Hz

For couplings with progressive torsional stiffness only the pre-load value changes as stated.

The tolerance of the torsional stiffness is  $\pm 15\%$  if not stated otherwise.

The following influences need to be considered if the torsional stiffness is required for other operating modes:

- Temperature  
Higher temperature reduces the dynamic torsional stiffness.  
Temperature factor  $S_{T_{C_{Tdyn}}}$  has to be taken into consideration in the calculation.
- Frequency of vibration  
Higher frequencies increase the torsional stiffness.  
By experience the dynamic torsional stiffness is 30% higher than the static stiffness. CENTA keeps record of exact parameters.
- Amplitude of vibratory torque  
Higher amplitudes reduce the torsional stiffness, therefore small amplitudes result in higher dynamic stiffness. CENTA keeps record of exact parameters.

8
Relative damping $\psi$

The relative damping is the relationship of the damping work to the elastic deformation during a cycle of vibration.

The larger this value [ $\psi$ ], the lower is the increase of the continuous vibratory torque within or close to resonance.

The tolerance of the relative damping is  $\pm 20\%$ , if not otherwise stated.

The relative damping is reduced at higher temperatures.

Temperature factor  $S_{T_{\psi}}$  has to be taken into consideration in the calculation.

The vibration amplitude and frequency only have marginal effect on the relative damping.

9
Speed [ $\text{min}^{-1}$ ]

The maximum speed of the coupling element, which may occur occasionally and for a short period (e.g. overspeed).

$n_{max}$  The characteristics of mounted parts may require a reduction of the maximum speed (e.g. outer diameter or material of brake discs).

$n_d$  The maximum permissible speed of highly flexible coupling elements is normally 90% thereof.

10
Permissible axial displacement [mm]

$\Delta K_a$  The continuous permissible axial displacement of the coupling.  
This is the sum of displacement by assembly as well as static and dynamic displacements during operation.

$\Delta K_{a_{max}}$  The maximum axial displacement of the coupling, which may occur occasionally for a short period (e.g. extreme load).  
The concurrent occurrence of different kinds of displacements is handled in technical documents (displacement diagrams, data sheets, assembly instructions).

# CENTADISC-C

## EXPLANATION OF THE TECHNICAL DATA

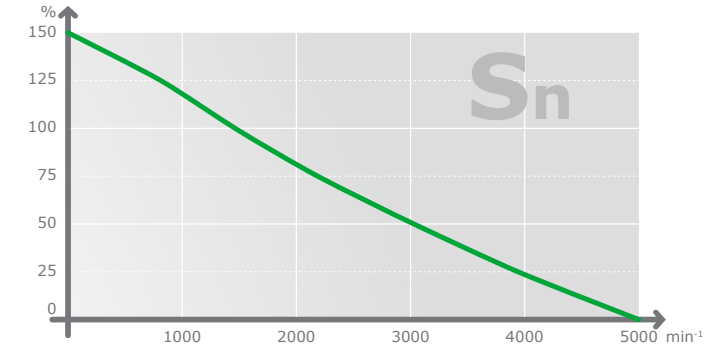

11	
Axial stiffness [kN/mm]	
$C_a$	The axial stiffness determines the axial reaction force on the input and output sides upon axial displacement.
$C_{a\ dyn}$	By experience the dynamic stiffness is higher than the static one. The factor depends on the coupling series.

12	
Permissible radial displacement [mm]	
$\Delta K_r$	The continuous permissible radial displacement of the coupling. This is the sum of displacement by assembly as well as static and dynamic displacements during operation. The continuous permissible radial displacement depends on the operation speed and may require adjustment (see diagrams $S_n$ of the coupling series).
$\Delta K_{r\ max}$	The maximum radial displacement of the coupling, which may occur occasionally and for a short period without consideration of the operation speed (e.g. extreme overload). The concurrent occurrence of different kinds of displacements is handled in technical documents (displacement diagrams, data sheets, assembly instructions).

13	
Radial stiffness [kN/mm]	
$C_r$	The radial stiffness determines the radial reaction force on the input and output sides upon radial displacement.
$C_{r\ dyn}$	By experience the dynamic stiffness is higher than the static one. The factor depends on the coupling series.

14	
Permissible angular displacement [°]	
$\Delta K_w$	The continuous permissible angular displacement of the coupling. This is the sum of displacement by assembly as well as static and dynamic displacements during operation. The continuous permissible angular displacement depends on the operation speed and may require adjustment (see diagrams $S_n$ of the coupling series).
$\Delta K_{w\ max}$	The maximum angular displacement of the coupling, which may occur occasionally and for a short period without consideration of the operation speed (e.g. extreme overload). The concurrent occurrence of different kinds of displacements is handled in technical documents (displacement diagrams, data sheets, assembly instructions).

15	
Angular stiffness [kNm/°]	
$C_w$	The angular stiffness determines the restoring bending moment on the input and output sides upon angular displacement.
$C_{w\ dyn}$	By experience the dynamic stiffness is higher than the static one. The factor depends on the coupling series.



CENTADISC-C

© 2018 by CENTA Antriebe Kirschey GmbH

Rev. CD-C-EN-10-18

1. This catalog supersedes previous editions.

This catalog shows the extent of our CENTAX®-SEC coupling range at the time of printing. This program is still being extended with further sizes and series. Any changes due to technological progress are reserved.

We reserve the right to amend any dimensions or detail specified or illustrated in this publication without notice and without incurring any obligation to provide such modification to such couplings previously delivered. Please ask for an application drawing and current data before making a detailed coupling selection.

2. We would like to draw your attention to the need of preventing accidents or injury. No safety guards are included in our supply.

3. TRADEMARKS

CENTA, the CENTA logo, Centacone, CENTADISC, CENTAFIT, Centaflex, CENTALINK, Centalock, Centaloc, Centamax, Centastart, CENTAX, HYFLEX and CENTAWAVE are registered trademarks of CENTA Antriebe Kirschey GmbH in Germany and other countries.

Other product and company names mentioned herein may be trademarks of their respective companies.

4. Torsional responsibility

The responsibility for ensuring the torsional vibration compatibility of the complete drive train, rests with the final assembler. As a component supplier CENTA is not responsible for such calculations, and cannot accept any liability for gear noise/-damage or coupling damage caused by torsional vibrations.

CENTA recommends that a torsional vibration analysis (TVA) is carried out on the complete drive train prior to start up of the machinery. In general torsional vibration analysis can be undertaken by engine manufacturers, consultants or classification societies. CENTA can assist with such calculations using broad experience in coupling applications and torsional vibration analysis.

5. Copyright to this technical dokument is held by CENTA Antriebe Kirschey GmbH.

6. The dimensions on the flywheel side of the couplings are based on the specifications given by the purchaser. The responsibility for ensuring dimensional compatibility rests with the assembler of the drive train. CENTA cannot accept liability for interference between the coupling and the flywheel or gearbox or for damage caused by such interference.

7. All technical data in this catalog are according to the metric SI system. All dimensions are in mm. All hub dimensions ( $N$ ,  $N_1$  and  $N_2$ ) may vary, depending on the required finished bore. All dimensions for masses ( $m$ ), inertias ( $J$ ) and centres of gravity ( $S$ ) refer to the maximum bore diameter.

CENTA Power Transmission is now part of Rexnord.  
As a global leader in premium couplings,  
Rexnord provides the same high quality customer  
solutions and service you've come to expect  
from CENTA since 1970.



[WWW.CENTA.INFO/CONTACT](http://WWW.CENTA.INFO/CONTACT)

[WWW.REXNORD.COM](http://WWW.REXNORD.COM)

**CENTA  
HEAD OFFICE**

CENTA Antriebe  
Kirschey GmbH  
Bergische Strasse 7  
42781 Haan/Germany  
+49-2129-912-0 Phone  
+49-2129-2790 Fax  
info@centa.de

**REXNORD POWER TRANSMISSION  
HEAD OFFICE**

4701 W Greenfield Ave  
Milwaukee, WI 53214  
USA

+1-414-643-3000 Phone